

Additional Extras - COUNTERS

Please see range of available counters all of which can be used for product display or as information / reception desks. All counters are supplied with white panels and white worktops as standard (upgrades available). All exclude artwork printing and power sockets.

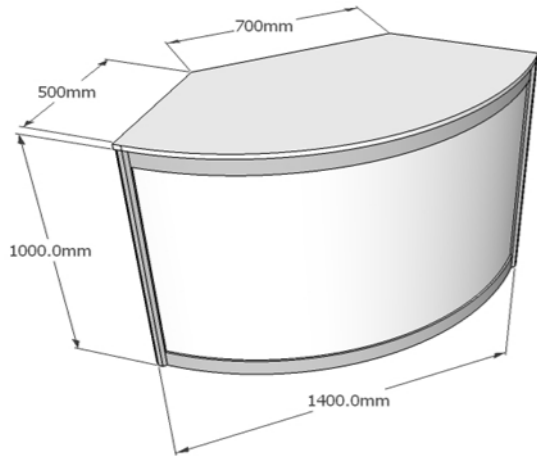

Counter #1
Includes lockable door to rear
plus internal shelf

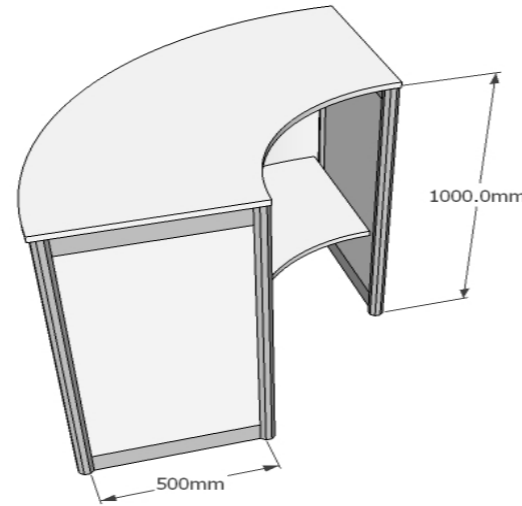

Counter #2
As per Counter #1
Excludes lockable door

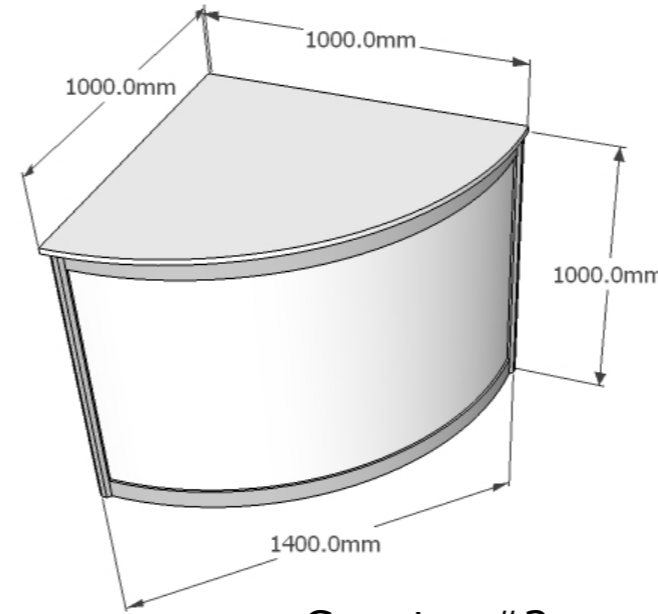

Counter #3
Quarter Circle
Lockable door to rear
Excludes internal shelf

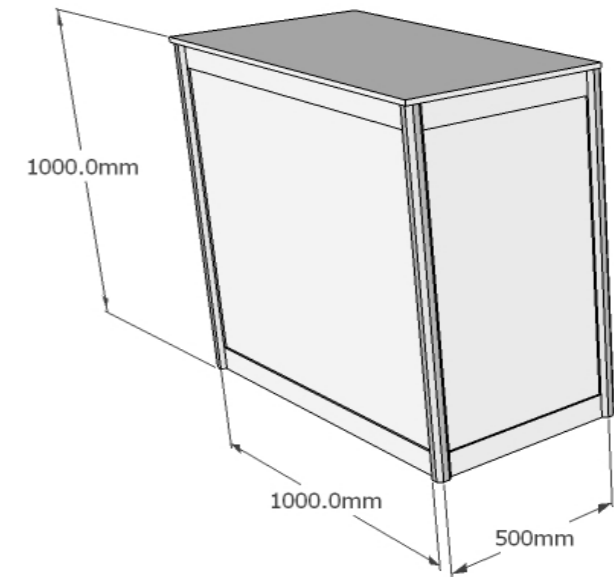

Counter #4
Includes internal shelf
plus lockable doors

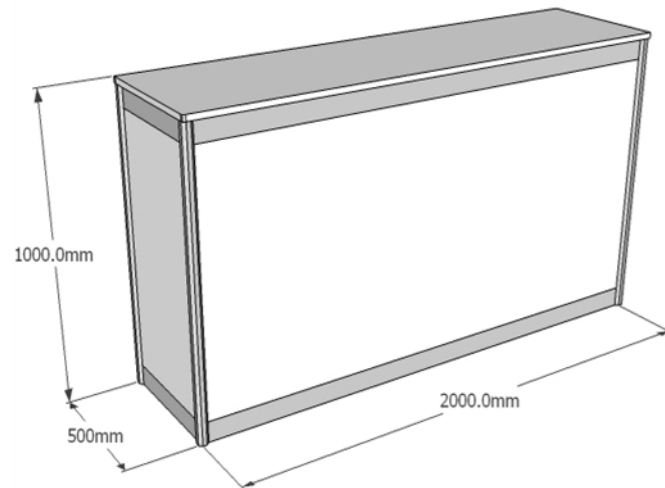

Counter #5
Includes internal shelf
plus lockable doors to rear

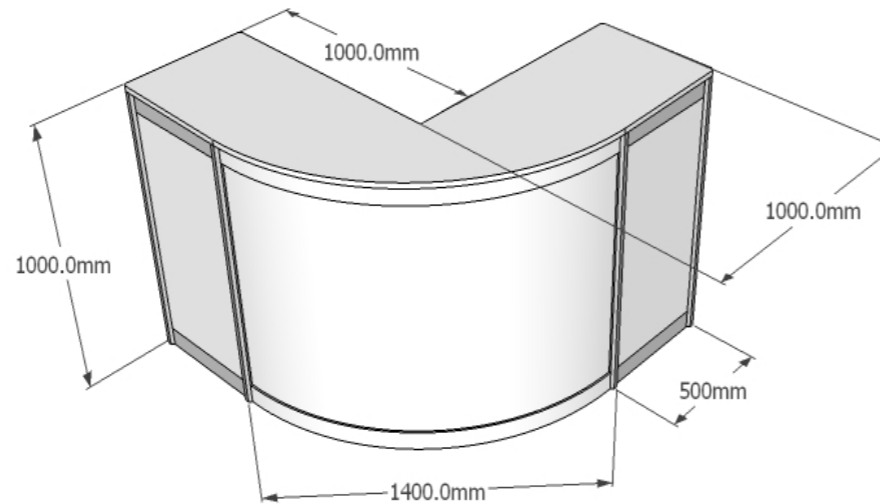

Counter #6
Includes internal shelf
plus lockable doors (2)

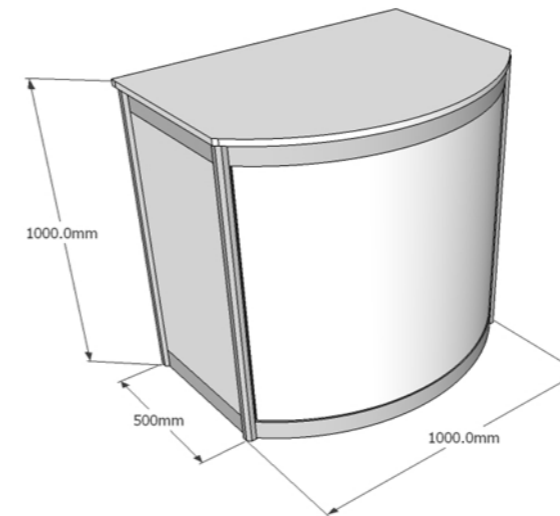

Counter #7
As per counter #4
with curved front

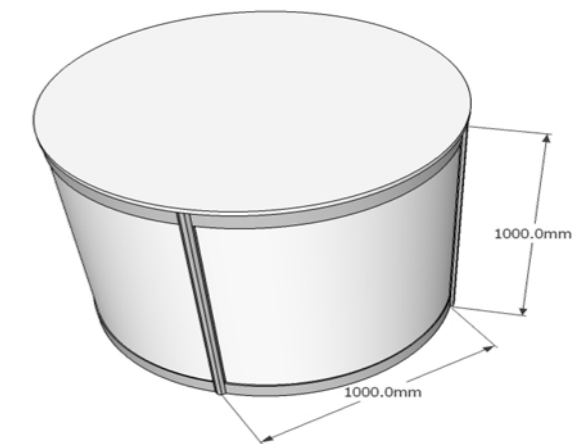

Counter #8
1.4m diameter
No access inside





Additional Items – Counters

COUNTERS

S27	Counter #1	See Exhibitor Pack	Each
S28	Counter #2 (not lockable)	See Exhibitor Pack	Each
S29	Counter #3	See Exhibitor Pack	Each
S30	Counter #4	See Exhibitor Pack	Each
S31	Counter #5	See Exhibitor Pack	Each
S32	Counter #6	See Exhibitor Pack	Each
S33	Counter #7	See Exhibitor Pack	Each
S34	Counter #8 (no access inside)	See Exhibitor Pack	Each
S31	Lockable doors to counters, pods or plinths	See Exhibitor Pack	Each

All furniture items are on hire only. All images illustrated in brochure are for guidance only, exact shades and styles may vary slightly from illustration. In all cases we will endeavour to deliver the exact chosen item, in any cases where this is not possible, we will inform you in advance of the event. Please note specific items cannot be reserved, although a quotation may specify a particular code, this item is not guaranteed until the SmartSpace agreement is signed and returned. It is not possible to book furniture items on our system until you have confirmed your order with us, and an invoice is raised.

Terms & Conditions:

1. All items are on hire only.
2. Prices quoted are for the duration of the event only, and do not include use for any future events.
3. Prices do not reflect any storage or refurbishment use for future events.
4. It remains the client's responsibility to ensure items are not damaged or tampered during the event. If damage or breakages occur not as a direct result of wear and tear, charges will apply to replace / repair items.
5. Prices quoted above are applicable BEFORE the stated deadline only. Surcharges will apply to any orders placed after the stated deadline.
6. Orders will not be confirmed until the SmartSpace agreement is signed, and an invoice issued. It is not possible to confirm items of stock until this is done; therefore it is advisable to confirm your SmartSpace stand booking well in advance to the deadline date.
7. The Terms and Conditions of Reed Exhibitions (To be found on the reverse of your paper copy contract) apply in all cases.



Additional Items – Counters Tops

COUNTER TOPS

Code	Description	Price	Item
WT1	Counter #1 worktop upgrade	£15	Each
WT2	Counter #2 worktop upgrade	£15	Each
WT3	Counter #2 internal shelf upgrade	£15	Each
WT4	Counter #3 worktop upgrade	£30	Each
WT5	Counter #4 worktop upgrade	£10	Each
WT6	Counter #5 worktop upgrade	£20	Each
WT7	Counter #6 worktop upgrade	£25	Each
WT8	Counter #7 worktop upgrade	£15	Each
WT9	Counter #8 worktop upgrade	£50	Each
WT10	PLASMA #1 worktop upgrade	£15	Each
WT11	TOWER #2 worktop upgrade (you will need to order 2no)	£15	Each
WT12	TOWER #2 ceiling panel upgrade (you will need to order 2no)	£15	Each
WT13	TOWER #3 worktop upgrade	£15	Each
WT14	TOWER #4 worktop upgrade	£30	Each
WT15	Standard shelf 1m wide x 30cm deep	£15	Each

Terms & Conditions:

1. All items are on hire only.
2. Prices quoted are for the duration of the event only, and do not include use for any future events.
3. Prices do not reflect any storage or refurbishment use for future events.
4. It remains the client's responsibility to ensure items are not damaged or tampered during the event. If damage or breakages occur not as a direct result of wear and tear, charges will apply to replace / repair items.
5. Prices quoted above are applicable BEFORE the stated deadline only. Surcharges will apply to any orders placed after the stated deadline.
6. Orders will not be confirmed until the SmartSpace agreement is signed, and an invoice issued. It is not possible to confirm items of stock until this is done; therefore it is advisable to confirm your SmartSpace stand booking well in advance to the deadline date.
7. The Terms and Conditions of Reed Exhibitions (To be found on the reverse of your paper copy contract) apply in all cases.